

EJERCICIO DE APLICACIÓN METODO DE LAS DEFORMACIONES PARA ESTRUCTURAS ACARTELADAS

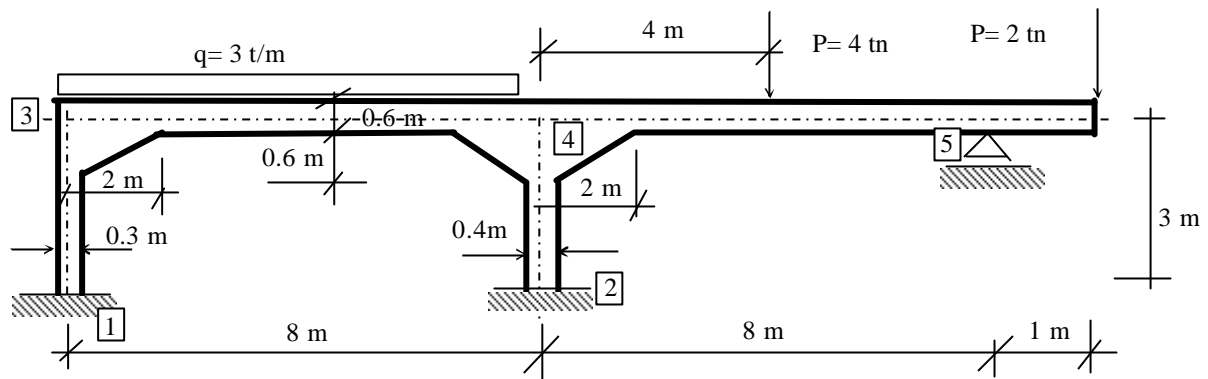

La ecuación de recurrencia vista en teoría para una barra genérica "ij" era:

$$M_{ij} = M^0_{ij} + \frac{4.E.I_{ij}}{L_{ij}} [k_i \cdot \omega_i + k_i \cdot m_i \omega_j - k_i (1 + m_i) \cdot \psi_{ij}]$$

multiplicando y dividiendo por I_0 el segundo miembro de la ecuación anterior obtenemos:

$$M_{ij} = M^0_{ij} + \frac{4.E.I_{ij}}{L_{ij}} \cdot \frac{I_0}{I_0} [k_i \cdot \omega_i + k_i \cdot m_i \omega_j - k_i (1 + m_i) \cdot \psi_{ij}] =$$

$$= M^0_{ij} + \frac{4 \cdot \alpha_{ij}}{L_{ij}} \left[k_i \cdot \bar{\omega}_i + k_i \cdot m_i \bar{\omega}_j - k_i (1 + m_i) \cdot \bar{\psi}_{ij} \right]$$

siendo:

$$\alpha_{ij} = I_{ij} / I_0$$

$$\bar{\omega}_i = \omega_i \cdot E \cdot I_0 \quad \bar{\omega}_j = \omega_j \cdot E \cdot I_0 \quad \bar{\psi}_{ij} = \psi_{ij} \cdot E \cdot I_0$$

$$I_{13} = b \times 0.3^3 / 12$$

$$I_{24} = b \times 0.4^3 / 12$$

$$I_{34} = I_{45} = b \times 0.6^3 / 12 \quad \text{tomamos } I_0 = I_{34} = I_{45}$$

$$\alpha_{13} = 0.125 \quad \alpha_{24} = 0.296 \quad \alpha_{34} = 1.00 \quad \alpha_{45} = 1.00$$

Datos:

por condición de vínculo

$$\omega_1 = \omega_2 = \psi_{34} = \psi_{45} = 0$$

Incógnitas:

$$\omega_3; \omega_4; \omega_5; \psi_{13}; \psi_{24}$$

Cómo el método no considera deformaciones por esfuerzo normal, entonces el desplazamiento horizontal de los nudos 3, 4 y 5 será el mismo.

Luego:

$$\Delta = L_{13} \cdot \psi_{13} = L_{24} \cdot \psi_{24} \rightarrow \psi_{13} = L_{24} / L_{13} \cdot \psi_{24}$$



Cálculo de k_i, m_i, r

Barra 1-3

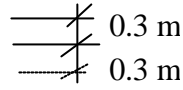
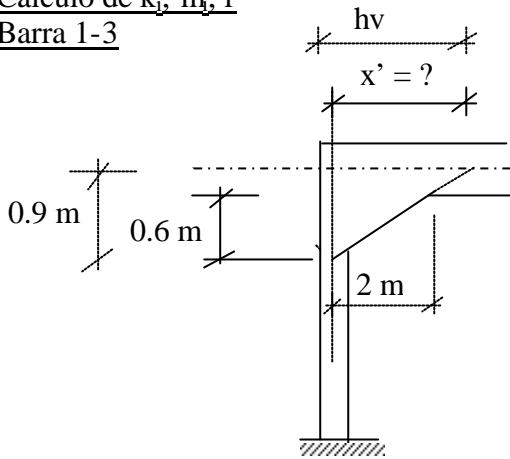

$$\frac{2.00 \text{ m}}{0.60 \text{ m}} = \frac{x'}{0.90 \text{ m}}$$

→ $x' = 3.00 \text{ m}$

$h_v = 3.00 + 0.15 = 3.15$

$h_c = 0.3 \text{ m}$ $h_v = 3.15 \text{ m}$
 $a = v / l = 0.30$ $i = I_c / I_v = h_c^3 / h_v^3 = 0$

de tabla 7 obtenemos:

$k_1 = 1.45$ $m_1 = 1.148$

de tabla 6 obtenemos:

$k_3 = 4.11$ $m_3 = 0.404$

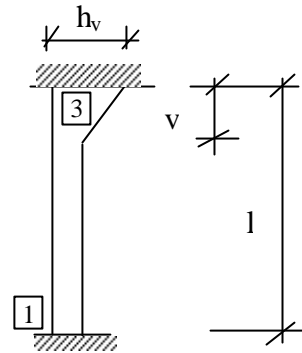

Barra 2-4

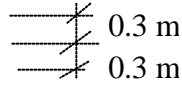
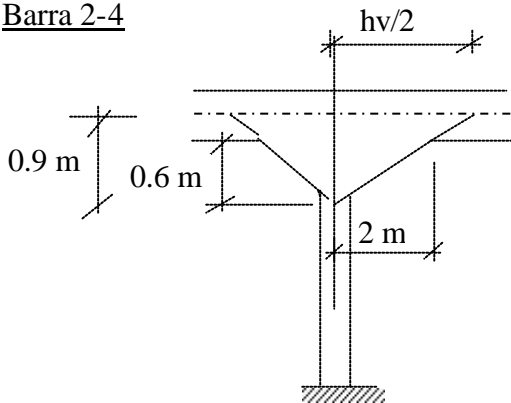

$$\frac{2.00 \text{ m}}{0.60 \text{ m}} = \frac{h_v/2}{0.90 \text{ m}}$$

→ $h_v/2 = 3.00 \text{ m}$

$h_c = 0.4 \text{ m}$ $h_v = 6.00 \text{ m}$
 $a = v / l = 0.9/0.3 = 0.30$ $i = 0$

de tabla 7 obtenemos:

$k_2 = 1.45$ $m_2 = 1.148$

de tabla 6 obtenemos:

$k_4 = 4.11$ $m_4 = 0.404$

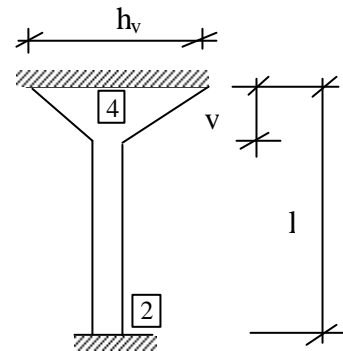

Barra 3-4

$h_c = 0.6 \text{ m}$ $h_v = 1.20 \text{ m}$
 $a = v / l = 0.25$ $i = 0.125$

de tabla 5 obtenemos:

$k_3 = k_4 = 2.437$ $m = 0.69$

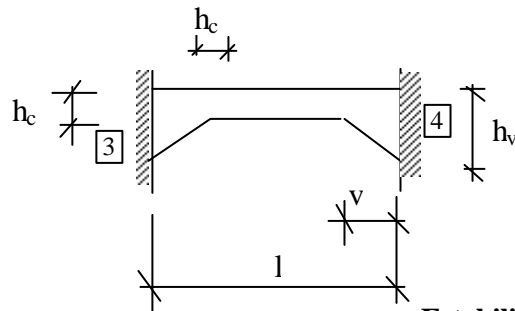

Barra 4-5

$$h_c = 0.6\text{m} \quad h_v = 1.20\text{ m}$$

$$a = v / l = 0.25 \quad i = 0.125$$

de tabla 6 obtenemos:

$$k_4 = 1.893 \quad m_4 = 0.462$$

de tabla 7 obtenemos:

$$k_5 = 1.155 \quad m_5 = 0.750$$

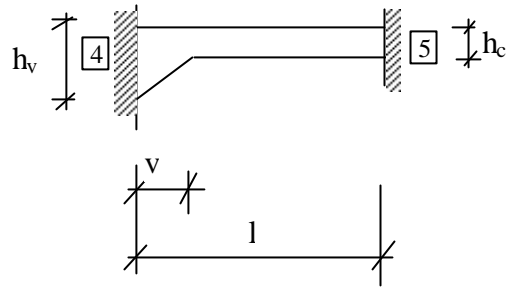
Cálculo de los M_{ij}^0 Barra 3-4

de tabla 1 obtenemos:

$$r_3 = r_4 = 0.1015$$

$$M_{34}^0 = -M_{43}^0 = r \cdot q \cdot l^2 = 0.1015 \times 3 \times 8^2 = 19.49\text{ tm}$$

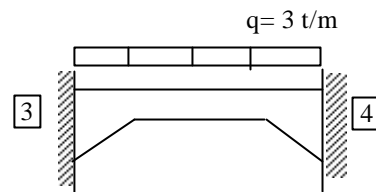
Barra 4-5

De tabla (para P en el punto 3)

$$\eta_4 = 0.1874 \quad \eta_5 = 0.0987$$

$$M_{45}^0 = \eta_4 P \cdot l = 0.1874 \times 4 \times 8 = 6.00\text{ tm}$$

$$M_{54}^0 = -\eta_5 P \cdot l = -0.0987 \times 4 \times 8 = -3.158\text{ tm}$$

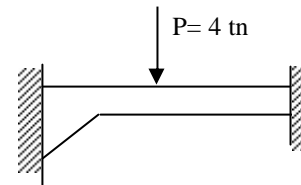

Planteamos las ecuaciones de recurrencia para cada barra

$$M_{ij} = M_{ij}^0 + \frac{4 \cdot \alpha_{ij}}{L_{ij}} \left[k_i \cdot \bar{\omega}_i + k_j \cdot m_j \cdot \bar{\omega}_j - k_i (1 + m_j) \cdot \bar{\psi}_{ij} \right]$$

Barra 1-3

$$M_{13} = M_{13}^0 + \frac{4 \cdot \alpha_{13}}{L_{13}} \left[k_1 \cdot \bar{\omega}_1 + k_3 \cdot m_3 \cdot \bar{\omega}_3 - k_1 (1 + m_3) \cdot \bar{\psi}_{13} \right]$$

$$M_{13} = 0 + \frac{4 \times 0.125}{3\text{m}} \left[1.45 \times 0 + 1.45 \times 1.148 \times \bar{\omega}_3 - 1.45 \times (1 + 1.148) \cdot \bar{\psi}_{13} \right]$$

$$M_{13} = 0.2774 \bar{\omega}_3 - 0.5191 \bar{\psi}_{13}$$

$$M_{31} = 0.685 \bar{\omega}_3 - 0.9617 \bar{\psi}_{13}$$

Barra 2-4

$$M_{24} = 0 + \frac{4 \times 0.296}{3\text{m}} \left[1.45 \times 0 + 1.45 \times 1.148 \bar{\omega}_4 - 1.45 \times (1 + 1.148) \cdot \bar{\psi}_{24} \right]$$

$$M_{24} = 0.657 \bar{\omega}_4 - 1.229 \bar{\psi}_{24}$$



$$M_{42} = 0 + \frac{4 \times 0.296}{3m} \left[4.11 \times \bar{\omega}_4 + 0 - 4.11(1 + 0.404) \cdot \bar{\psi}_{24} \right]$$

$$M_{42} = 1.622 \bar{\omega}_4 - 2.277 \bar{\psi}_{24}$$

Barra 3-4

$$M_{34} = 19.49 + \frac{4 \times 1.00}{8m} \left[2.437 \times \bar{\omega}_3 + 2.437 \times 0.69 \bar{\omega}_4 - 0 \right]$$

$$M_{34} = 19.49 + 1.2185 \bar{\omega}_3 + 0.8407 \bar{\omega}_4$$

$$M_{43} = -19.49 + 0.8407 \bar{\omega}_3 + 1.2185 \bar{\omega}_4$$

Barra 4-5

$$M_{45} = 6.00 + \frac{4 \times 1.00}{8m} \left[1.893 \times \bar{\omega}_4 + 1.893 \times 0.462 \bar{\omega}_5 - 0 \right]$$

$$M_{45} = 6 + 0.9465 \bar{\omega}_4 + 0.4372 \bar{\omega}_5$$

$$M_{54} = -3.158 + \frac{4 \times 1.00}{8m} \left[1.155 \bar{\omega}_5 + 1.155 \times 0.749 \bar{\omega}_4 - 0 \right]$$

$$M_{54} = -3.158 + 0.5775 \bar{\omega}_5 + 0.4325 \bar{\omega}_4$$

Planteo de las ecuaciones de equilibrio

Sumatoria de momentos en nudos 3, 4, y 5 igual a cero, tenemos tres ecuaciones y cuatro incógnitas, necesito una ecuación de equilibrio adicional → ecuación de piso (sumatoria de fuerzas horizontales igual a cero)

Equilibrio de momentos en el nudo 3

$$\sum M_3 = 0$$

$$M_{31} + M_{34} = 0$$

Para hacer el equilibrio de nudos tomamos
Acción de barra sobre nudo
(positivo en sentido horario)

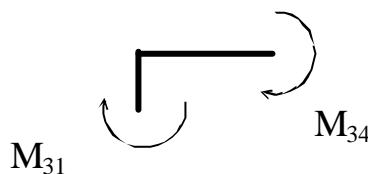

$$M_{31} \rightarrow 0.00 \quad +0.685 \omega_3 \quad -0.9617 \psi_{13}$$

$$M_{34} \rightarrow 19.49 \quad +1.2175 \omega_3 \quad +0.8407 \omega_4$$

	+19.49	+1.9035 ω_3	+0.8407 ω_4	-0.9617 $\psi_{13} = 0$ (I)
--	--------	--------------------	--------------------	-----------------------------

Equilibrio de momentos en el nudo 4

$$\sum M_4 = 0$$

$$M_{43} + M_{42} + M_{45} = 0$$

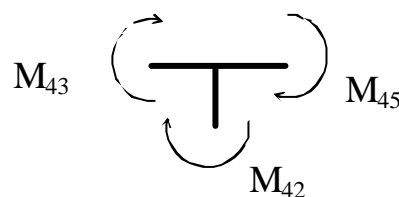

$$\begin{array}{r}
 M_{43} \rightarrow + \quad -19.49 \quad +0.8407 \omega_3 \quad +1.2175 \omega_4 \\
 M_{42} \rightarrow \quad \quad \quad \quad \quad \quad +1.6220 \omega_4 \quad -2.277\psi_{24} \\
 M_{45} \rightarrow \quad +6.00 \quad \quad \quad +0.9165 \omega_4 \quad +0.4372 \omega_5 \\
 \hline
 \quad \quad -13.49 \quad +0.8407\omega_3 \quad + 3.787 \omega_4 \quad +0.4372 \omega_5 \quad -2.277 \psi_{24}= 0 \quad (\text{II})
 \end{array}$$

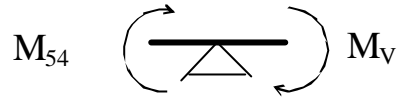
Equilibrio de momentos en el nudo 3

$$\sum M_5 = 0$$

$$M_{54} + M_v = 0$$

$$M_{54} \rightarrow + \quad -3.158 \quad +0.4325 \omega_4 \quad + 0.5775 \omega_5$$

$$M_v \rightarrow \quad +2.000$$

$$\begin{array}{r}
 \quad \quad -1.158 \quad +0.4325\omega_4 \quad +0.5775\omega_5 = 0 \quad (\text{III})
 \end{array}$$

Ecuación de piso

$$\sum F_H = 0$$

$$+ Q_{31} + Q_{42} = 0$$

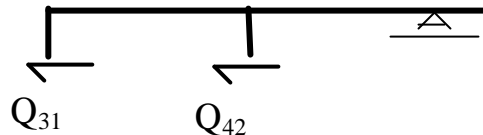

Nota. Para hallar los esfuerzos de corte debidos al momento flector en las distintas barras aplico momentos positivos (ya que todavía no conozco su valor) en los extremos de barras. (Acción de nudo sobre barra positivo en sentido antihorario)

$$Q_{31}^M = (M_{31} + M_{13}) / L_{13} = 0.3208 \omega_3 - 0.4936 \psi_{13}$$

$$Q_{42}^M = (M_{24} + M_{42}) / L_{24} = 0.7597 \omega_4 - 1.1687 \psi_{24}$$

$$\sum F_H = 0$$

$$Q_{31}^M \rightarrow \quad 0.3208 \omega_3 \quad -0.4936 \psi_{13}$$

$$Q_{42}^M \rightarrow \quad \quad \quad 0.7597 \omega_4 \quad -1.1689 \psi_{13}$$

$$\begin{array}{r}
 \quad \quad 0.3208\omega_3 \quad +0.7597 \omega_4 \quad -1.6625 \psi_{13} = 0 \quad (\text{IV})
 \end{array}$$

En la ecuación anterior se tuvo en cuenta que $\psi_{13} = L_{24} / L_{13} \cdot \psi_{24} = \psi_{24}$

Resolviendo el sistema de ecuaciones obtenemos:

$$\bar{\omega}_3 = -13.0697 \quad \bar{\omega}_4 = 7.3827 \quad \bar{\omega}_5 = -3.5224 \quad \bar{\psi}_{13} = 0.85149$$

Reemplazando los valores de las rotaciones en las ecuaciones de recurrencia obtenemos los momentos flectores en las barras y a partir de los mismos los esfuerzos de corte, normal y diagrama del cuerpo libre.



$$\begin{array}{llll}
 M_{13} = -4.07 \text{ tm} & M_{24} = 3.80 \text{ tm} & M_{34} = 9.77 \text{ tm} & M_{45} = 11.44 \text{ tm} \\
 M_{31} = -9.77 \text{ tm} & M_{42} = 10.04 \text{ tm} & M_{43} = -21.48 \text{ tm} & M_{54} = -2.00 \text{ tm}
 \end{array}$$

DIAGRAMA DE MOMENTOS



DIAGRAMA DE CORTE



DIAGRAMA DE N

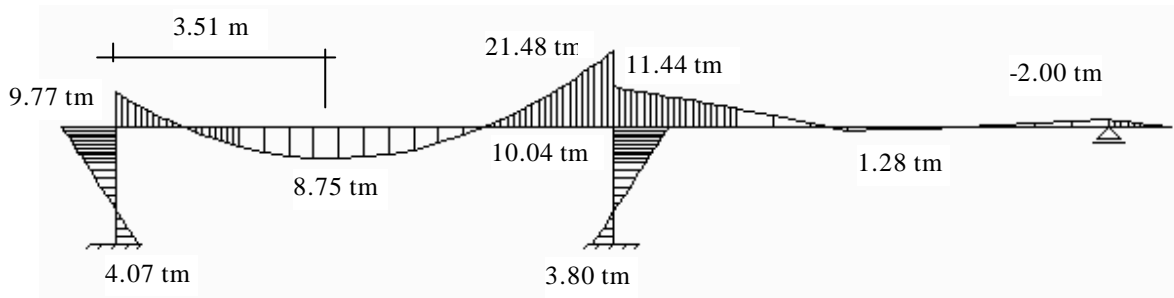

ESTRUCTURA DEFORMADA

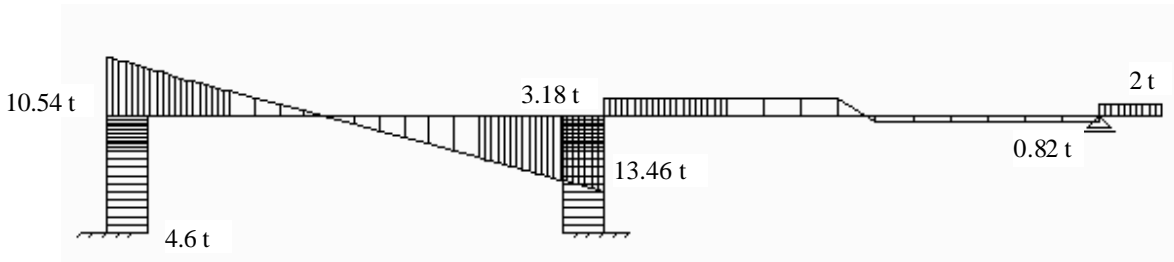
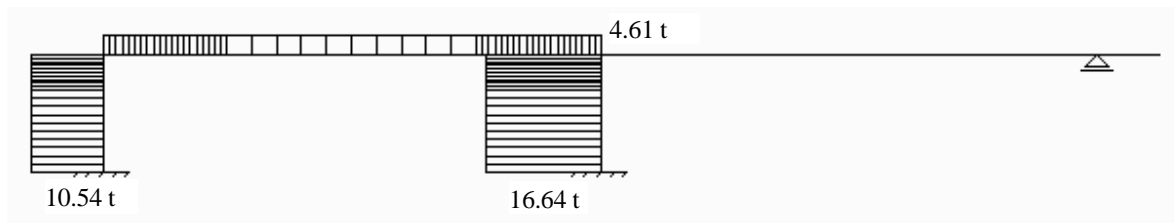
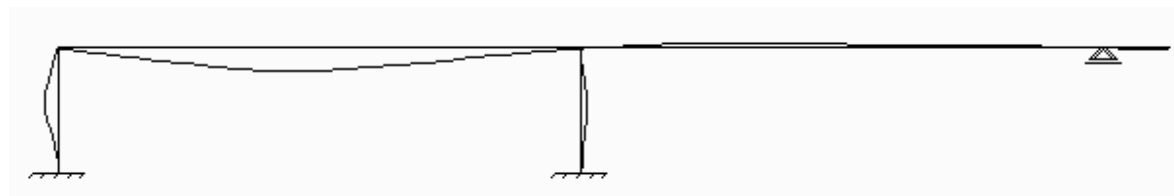

DIAGRAMA DEL CUERPO LIBRE

